

SENSOR | OQSX-G2

Product No.: OQSXG2-I-AA-02-5



PRODUCT DESCRIPTION

Tan Delta's OQSx-G2 is the world's most advanced real-time oil condition sensor delivering a unique insight into the current status of your equipment. Easily fitted, the OQSx-G2 will continuously monitor, measure and report actual oil condition with absolute accuracy and reliability with simple plug & play data interface into your existing display and monitoring systems.

The OQSx-G2 works with any oil type, mineral/synthetic, and can be fitted to any engine, gearbox, hydraulic or electrical transformer system whilst in full operation. Our unique FSH™ oil condition monitoring technology ensures any wear and or contamination is instantly detected, measured and reported with an oil quality change sensitivity detection of 0.01% (10ppm) with an accuracy margin of +/-0.5%

Simple to install and use, the OQSx-G2 provides unique insight into the condition of your equipment, helping you prevent unnecessary breakdowns, eliminate unnecessary maintenance and reduce your operating costs.

KEY FEATURES

- **FULL SPECTRUM HOLISTIC (FSH™)**

Detects all and any wear and contamination: water, acid, fuel, viscosity, different oil types, carbon, particles etc.

- **ABSOLUTE ACCURACY**

The FSH technology within our sensor enables it to have a oil quality change sensitivity detection of 0.01% (10ppm) with an accuracy margin of +/-0.5%.

- **REAL-TIME**

Continuously analyses oil condition on operating equipment and reports oil condition every two seconds.

- **ROBUST & RELIABLE**

Proven around the world for use in even the most extreme industrial and commercial applications.

- **EASY TO INSTALL**

Quick and easy to install on any equipment with plug & play integration with any existing data reporting and display systems.

BENEFITS

Every equipment operator knows that machine monitoring enables effective management and thus increased reliability, efficiencies and profits. Oil condition monitoring with Tan Delta takes this to a new level through much greater insight into the real condition of your equipment, delivering significantly enhanced financial and operating benefits.

- **REDUCE MAINTENANCE COSTS**

Eliminate unnecessary maintenance and equipment downtime by precisely identifying oil end-of-life and reliably predicting optimal maintenance schedules.

- **REDUCE BREAKDOWNS & DAMAGE**

Improve efficiency and extend the life of your equipment by ensuring optimal oil condition and reliable early detection of potential issues before wear particles are present and damage has already occurred.

- **REDUCE OIL SAMPLING**

Significantly reduce time consuming oil sampling and costly laboratory analysis.

TECHNICAL DATA

PRODUCT INFORMATION

Name	Gen 2 - Oil Quality Sensor
Product Number	OQSxG2-1-AA-02-5

PHYSICAL

Material	Stainless Steel AISI304
Dimensions	102mm x 36mm (L x W)
Weight	180g
Connection	32mm AF Hex Collar
Torque	25N.m

AVAILABLE THREADS

Thread	Seal
1/2" BSPP	Dowty Type
1/2" NPT	n/a
7/8" UNF	'O' Ring
M18	Dowty Type

(Alternative threads available upon request)

CONNECTIONS

Connector	6 pin Bulgin 4000 series
-----------	--------------------------

ELECTRICAL

Supply	+9-30V DC
Consumption	0.4w Average

DATA OUTPUT/INPUT

Digital Output	RS485, CANbus
Protocols Supported	Modbus, CanOpen and J1939
Analog Output	4-20mA

OIL QUALITY DETECTION PARAMETERS

Frequency	Every 2 seconds
Output	Tan Delta Number (TDN) Oil Temperature (C or F)
Sensitivity / Accuracy	0.01%, +/-0.5%
Elements	All wear and contamination

OIL TYPE

Configuration	Any mineral, semi-synthetic or synthetic oil, including fuels (diesel & bio-diesel)
---------------	---

ENVIRONMENTAL

Operating Temperature	-40°C (-40°F) to +120°C (+248°F)
Calibrated Temperature	-20°C (-4°F) to +120°C (+248°F)
Fluid Temperature	-40°C (-40°F) to +120°C (+248°F)
Fluid Pressure	up to 70 bar (1015 psi)
Storage Temperature	-55°C (-67°F) to +150°C (+302°F)

STANDARDS & CERTIFICATION

Water & Dust	IP68 when connected
Shock & Vibration	BS EN 60068-2-30 (Test Db - Cyc.Hum.) BS EN 60068-2-6 (Test Fc - Sine Vib.) BS EN 60068-2-27 (Test Ea - Mech. Shock)
EMC	EN 61000-6-4:2007 (Generic Emissions Standard for Industrial Environments) EN 61000-6-2:2005 (Generic Immunity Standard for Industrial Environments)
Conformity	CE Marked RoHS Compliant

DIMENSIONS & CONNECTION

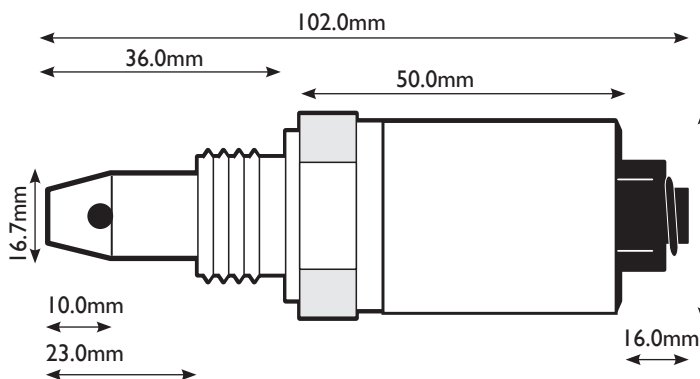

①	+9-30V DC
②	Oil Temperature - 4-20mA
③	Oil Condition - 4-20mA
④	RS485A / CANL
⑤	Ground / 0V
⑥	RS485B / CANH

WHY TAN DELTA

Tan Delta's advanced real-time oil condition monitoring is used by equipment owners around the world to improve reliability and reduce costs. Our core FSH technology delivers exceptional real-time oil analysis and condition insight. From wind turbines and ships to mining trucks and railways, Tan Delta real-time oil condition monitoring solutions are proven to deliver substantial operational and financial benefits. Our products are easy to install and use on any equipment and are fully supported by our dedicated support team.



Tan Delta provide OEM equipment manufacturers with fully customised integrated and cost optimised solutions. Please contact us directly to discuss your oil condition requirements.