

# KIT | EXPRESS DISPLAY

Product No.: OQ-EXP-I-G2



## PRODUCT DESCRIPTION

Everything you need for a single installation using the Oil Quality Sensor (OQSx-G2) and the OQD Express (OQDe) display. The kit includes a single OQSx-G2 sensor and a single OQDe display with all of the necessary cables for configuration and installation. Robust and easy to install, the OQSx-G2 and OQDe are the perfect partnership.

## KEY FEATURES

- **CONFIGURABLE OIL QUALITY ALERTS**

Configurable traffic light alert system provides simple visual oil quality reference.

- **DATA LOGGER**

Continuously logs up to 800,000 records of oil quality data which can be downloaded for analysis.

- **ESSENTIAL INFORMATION**

Displays oil quality, temperature and rate of change in real time.

- **FULL SPECTRUM HOLISTIC (FSH™)**

Detects all and any wear and contamination: water, acid, fuel, viscosity, different oil types, carbon, particles etc.

- **BLUETOOTH CONNECTIVITY**

Stored data can be easily downloaded and sent wherever needed.

- **INDEPENDENTLY TESTED**

Has undertaken rigorous independent testing to verify the outstanding performance in a wide variety of applications.

## BENEFITS

Every equipment operator knows that machine monitoring enables effective management and thus increased reliability, efficiencies and profits. Oil condition monitoring with Tan Delta takes this to a new level through much greater insight into the real condition of your equipment, delivering significantly enhanced financial and operating benefits.

- **REAL-TIME DATA**

Insight into potential failure modes through real-time trending and analysis of data.

- **REDUCE UNPLANNED DOWNTIME**

Reliable early detection of potential issues before wear particles are present and damage has already occurred, allows you to pinpoint optimal maintenance prior to breakdowns.

- **FLEXIBLE & EASY TO USE**

Deploy on any equipment operating in any environment - stand alone display/data logging or integration with existing monitoring systems.

## TECHNICAL DATA

### PRODUCT INFORMATION

Name	OQD Express (OQDe) Kit
Product Number	OQ-EXP-I

### PHYSICAL - SENSOR

Material	Stainless Steel AISI304
Dimensions	102mm x 36mm (L x W)
Weight	180g
Connection	32mm AF Hex Collar
Torque	25N·m
Connector	6 pin Bulgin 4000 series
Threads	Several available on request, including: 1/2" BSPP, 1/2" NPT, 7/8" UNF, M18

### PHYSICAL - DISPLAY

Material	Heat resistant polycarbonate
Dimensions	151 mm x 66mm x 42mm (L x W x H)
Weight	300g

### DATA LOGGING

Storage Capacity	<800,000 records
Logging Interval	1 minute to 45 days, 5 minutes fixed
Battery Backup	~10 years
Data Download	Digital or Bluetooth
Real Time Clock	Yes

### ELECTRICAL

Supply	+9-30V DC
Consumption	0.4w Average

### DATA OUTPUT/INPUT

Digital Output	1xRS485: 9600 baud half duplex to sensor 1xRS485: 512000 baud half duplex from display
Analog Output	4-20mA

### ENVIRONMENTAL

Sensor Temperature	-40°C (-40°F) to +120°C (+248°F)
Fluid Temperature	-40°C (-40°F) to +120°C (+248°F)
Fluid Pressure	up to 70 bar (1015 psi)
Storage Temperature	-55°C (-67°F) to +150°C (+302°F)

### STANDARDS & CERTIFICATION

Water & Dust	IP67 when connected BS EN 60529:1992+A2:2013
Shock & Vibration	BS EN 60068-2-30 (Test Db - Cyc.Hum.) BS EN 60068-2-6 (Test Fc - Sine Vib.) BS EN 60068-2-27 (Test Ea - Mech. Shock)
EMC	EN 61000-6-4:2007 (Generic Emissions Standard for Industrial Environments) EN 61000-6-2:2007 (Generic Immunity Standard for Industrial Environments) EN 300 328 v1.8.1. (Transferable Electromagnetic Compatibility for Wideband Data Transmission Equipment operating in the 2.4GHz ISM Band and using Wideband Modulation Techniques.)
Conformity	CE Marked RoHS Compliant

## DIMENSIONS

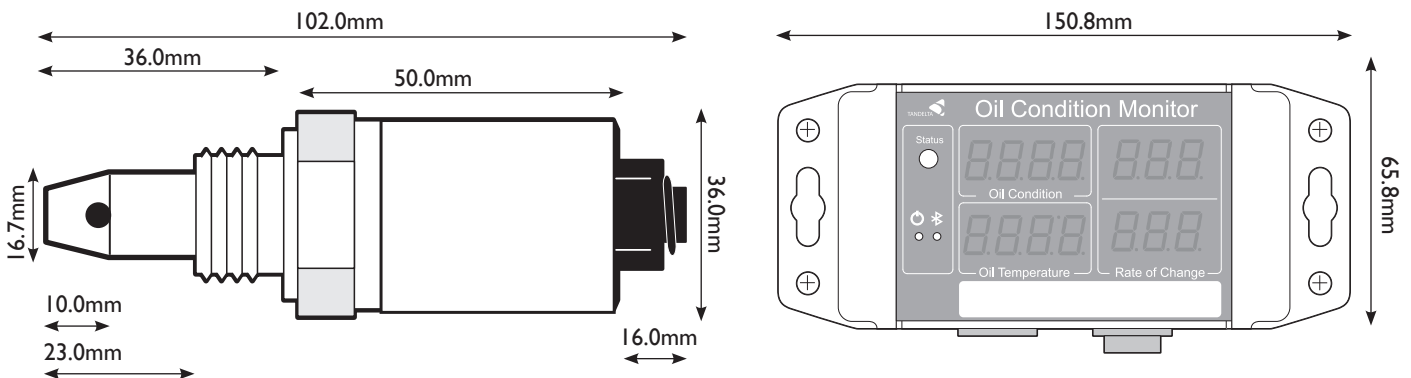

## WHY TAN DELTA

Tan Delta's advanced real-time oil condition monitoring is used by equipment owners around the world to improve reliability and reduce costs. Our core FSH technology delivers exceptional real-time oil analysis and condition insight. From wind turbines and ships to mining trucks and railways, Tan Delta real-time oil condition monitoring solutions are proven to deliver substantial operational and financial benefits. Our products are easy to install and use on any equipment and are fully supported by our dedicated support team.



Tan Delta provide OEM equipment manufacturers with fully customised integrated and cost optimised solutions. Please contact us directly to discuss your oil condition requirements.